

Steel fireplace NADIA 10 kW Ø 200 black thermotec

SKU: NADIA/10/BLACK EAN: 5902539503289



Technical data

General data

Version	Front facing
Rated output (kW)	10
Heating power range (kW)	5.0 - 12.5
Heating efficiency (%)	80
Exhaust gas temperature (°C)	255
Max length of logs (cm)	35
Min inlet grids active field (cm ²)	≥700
Min outlet grids active field (cm ²)	≥900
Flue outlet diameter (mm)	200
Color	Black
Self Closure	No
Materials	Steel
Door opening direction	Left

Energetic efficiency

Energy class	A
Energy efficiency index (EEI)	105.4
Moc cieplna do ogrzewania pomieszczeń (kW)	10
CO emissions (at 13% O ₂) ≤ given in %	0.1
Dust emission (mg/Nm ³)	32

Certifications / Compliance

Meets requirements

**KRATKI PRO, Ecodesign,
Designed for recuperation,
BlmSchV 2**

Additional information

Design features

**Air intake - built in ,
Combustion chamber
lining, Decorative glass**

Front type

**Steel front with painted
glass**

Type of fuel

**Seasoned deciduous wood
(humidity ≤20%)**

EAN

5902539503289

Physical parameters

Width (cm) **68.4**

Height (cm) **121.1**

Depth (cm) **41.8**

Weight (kg) **128**

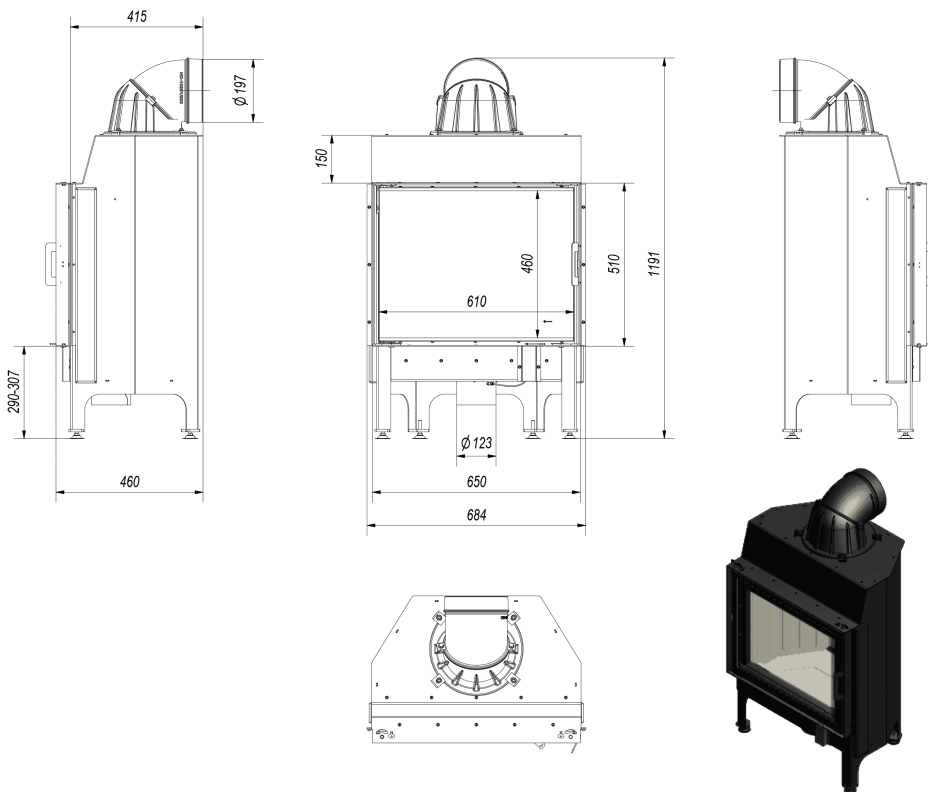

NADIA/10